

# OPERATING INSTRUCTIONS

**DINO  
105TL**

**Manufacturer:**

Dinolift Oy  
Raikkolantie 145 | FI-32210 LOIMAA  
Tel. + 358 20 1772 400 | [info@dinolift.com](mailto:info@dinolift.com) | [www.dinolift.com](http://www.dinolift.com)

---

---

**TRANSLATION OF THE ORIGINAL INSTRUCTIONS**

**Valid from serial number**

**105TL            10196 -**

## CONTENTS

<b>1.</b>	<b>TO THE OPERATOR</b> .....	<b>7</b>
1.1.	OVERVIEW OF THE UNIT.....	8
1.2.	INTENDED USE OF THE WORK PLATFORM.....	8
<b>2.</b>	<b>TECHNICAL SPECIFICATIONS</b> .....	<b>9</b>
2.1.	DIMENSION DRAWING.....	10
2.2.	REACH DIAGRAM.....	11
2.3.	EXAMPLE OF THE MACHINE'S NAMEPLATE.....	12
2.4.	EXAMPLE OF EU DECLARATION OF CONFORMITY.....	13
2.5.	SAMPLE OF INSPECTION PROTOCOL FOR THE ACCESS PLATFORM.....	14
<b>3.</b>	<b>SAFETY</b> .....	<b>16</b>
3.1.	SAFETY INSTRUCTIONS.....	16
3.2.	SAFETY-RELATED NOTIFICATIONS.....	20
3.3.	SAFETY DEVICES.....	22
<b>4.</b>	<b>STRUCTURE AND FUNCTIONS OF THE LIFT</b> .....	<b>24</b>
4.1.	STRUCTURE OF THE LIFT.....	24
4.2.	FUNCTIONS OF THE WORK PLATFORM.....	25
4.3.	OPERATING CONTROLS FOR THE FUNCTIONS.....	26
4.3.1.	Operating controls in the chassis control centre.....	26
4.3.2.	Operating controls for the outriggers.....	27
4.3.3.	Operating controls in the platform control centre.....	28
<b>5.</b>	<b>OPERATING INSTRUCTIONS</b> .....	<b>29</b>
5.1.	START-UP.....	29
5.1.1.	Worksite inspection.....	29
5.1.2.	Positioning the lift.....	30
5.1.3.	Starting up.....	31
5.1.4.	Supporting the lift.....	31
5.2.	OPERATION.....	32
5.2.1.	Operating the lift from the chassis control centre.....	32
5.2.2.	Operating the lift from the platform control centre.....	33
5.2.3.	Special instructions for winter use.....	35
5.2.4.	Ending the work.....	35
5.3.	TRANSFERRING THE LIFT.....	36
5.3.1.	Preparing the lift for transport.....	36
5.3.2.	Using the driving device.....	37
5.3.3.	Towing the lift.....	39
5.3.4.	Lifting the device.....	40
5.4.	LONG-TERM STORAGE.....	41

---

5.3.	IN CASE OF EMERGENCY .....	42
5.3.1.	When at risk of losing the stability .....	42
5.3.2.	In case of overloading.....	42
5.3.3.	In case the power supply is interrupted .....	42
5.3.4.	In case of malfunction, when even the emergency descent system is not operational	43
<b>6.</b>	<b>INSTRUCTIONS FOR FAULT-FINDING .....</b>	<b>44</b>
<b>7.</b>	<b>MAINTENANCE SCHEDULE.....</b>	<b>48</b>
7.1.	SCHEDULE FOR INSPECTIONS REQUIRED BY THE AUTHORITIES .....	50
7.2.	LUBRICATION PLAN .....	51
<b>8.</b>	<b>ROUTINE MAINTENANCE DURING OPERATION .....</b>	<b>52</b>
8.1.	INSTRUCTIONS FOR DAILY MAINTENANCE AND INSPECTIONS .....	53
8.1.1.	Check the condition of chassis, the boom and the work platform.....	53
8.1.2.	Check the tyres and tyre pressure.....	53
8.1.3.	Check the lights .....	53
8.1.4.	Check the hydraulic oil level .....	53
8.1.5.	Check the hydraulic hoses, pipes and connectors .....	53
8.1.6.	Check the operation of the safety limit switches.....	54
8.1.7.	Check the operation of the emergency descent, the emergency stop and the sound signal	54
8.1.8.	Stickers, plates and instructions .....	54
<b>9.</b>	<b>CHANGE OF OWNER.....</b>	<b>57</b>



**BLANK**

## 1. TO THE OPERATOR

Keep this manual on the work platform of the lift in the box reserved for it. If the instruction manual gets lost, damaged, or for some other reason becomes unreadable, order a new manual from the manufacturer.

This manual is intended to familiarise the user with the structure and functions of the work platform, as well as with its appropriate use. The manual provides guidance on the service measures that are the responsibility of the user of the work platform.

Other maintenance procedures on the work platform require special skills, special tools or accurate knowledge about measurements or adjusted values. Guidance for these measures is provided in a separate service manual. For situations that require service or repair measures, contact the authorised service provider, importer or manufacturer.



### **DANGER**

Read all the instructions in this manual before using the aerial work platform. Make sure that you have understood all the instructions. The instructions must absolutely be followed during operation and maintenance of the aerial work platform.

When handling the unit, in addition to the instructions in this manual, the user must also observe the local legislation, the guidelines stipulated by the employer, and regulations valid at the work site.

Dinolift Oy is constantly developing its products. For this reason, the contents of this manual might not always be in full compliance with the most recent version of the product. Dinolift Oy reserves the right to modify the product without prior notice. Dinolift Oy assumes no liability for any problems caused by changed or missing data or mistakes in this manual.

Please consult your dealer or the manufacturer for more information and detailed instructions.

## 1.1. OVERVIEW OF THE UNIT

This unit is a trailer mounted, towable aerial work platform.

This aerial work platform complies with the standard EN280 type 1. Moving the lift by means of the driving device or by towing is possible only when the lift is in the transport position.

For the operation, the tyres of the lift shall be raised off the ground by means of the hydraulic outriggers.

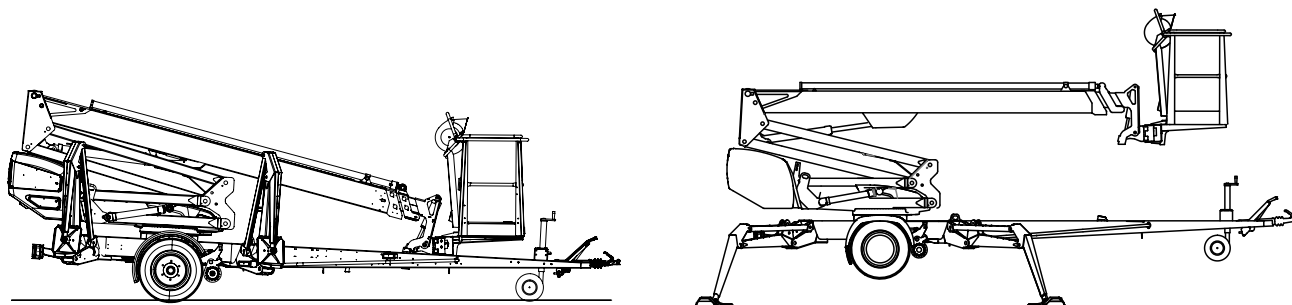

The primary power source of the lift is the electric motor. The outriggers and the boom system are hydraulically powered.

As an option, the lifts can be equipped with a hydraulic driving device.

Consult the chapters “Technical data” and “Structure and functions of the work platform” in this manual for more detailed information about the lift.

## 1.2. INTENDED USE OF THE WORK PLATFORM

The aerial work platform is exclusively intended for transferring people and tools to the work position and acting as a work platform within its permissible load-bearing capacity and reach (refer to the “Technical Specifications” table and the “Reach Diagram”).

The intended use also covers:

- Following all the instructions in the Operating Instructions
- Performance of the inspections and maintenance operations.
- Observation of the occupational safety regulations and road traffic regulations.

This aerial work platform is NOT insulated, and does not offer protection against contact with electric current. The aerial work platform must not be used for work on electric systems.

Observe the safety instructions concerning the operating environment, and the restrictions given in them,

### **NOTICE**

**The operator must receive instructions and consent from the manufacturer for all such specific work methods or conditions that the manufacturer has not explicitly defined in the unit's operation and maintenance instructions.**



## 2. TECHNICAL SPECIFICATIONS

		105TL
Max. working height		10.5 m
Max. platform height		8.5 m
Max. outreach to the side		6.5 m
Boom rotation		± 355°
Platform rotation		-
Turn area		refer to the reach diagram
Support width		3.57 m
Transport width		1.49 m
Transport length		5.45 m
Transport height		1.98 m
Weight		955 kg
Max. allowed load on platform		130 kg
Max. number of persons + additional load		1 person + 50 kg
Max. allowed sideways load (caused by persons)		200 N
Max. lateral inclination (chassis)		±0,3°
Maximum allowed gradient of ground to the side		
Maximum allowed gradient of ground lengthwise		
Max. wind speed during operation		12,5 m/s
Min. ambient temperature when working		-20 °C
Max. support force on the outriggers		7500 N
Platform size		0,7 x 0,85 m
Gradeability using the driving device (optional)		15%
Socket outlets on the platform		2 x 230V/50Hz/10A
Power supply		Mains current
		230V/50Hz/10A
	Sound pressure level	< 70 dB
	Whole-body vibration	Not detectable

2.1. DIMENSION DRAWING

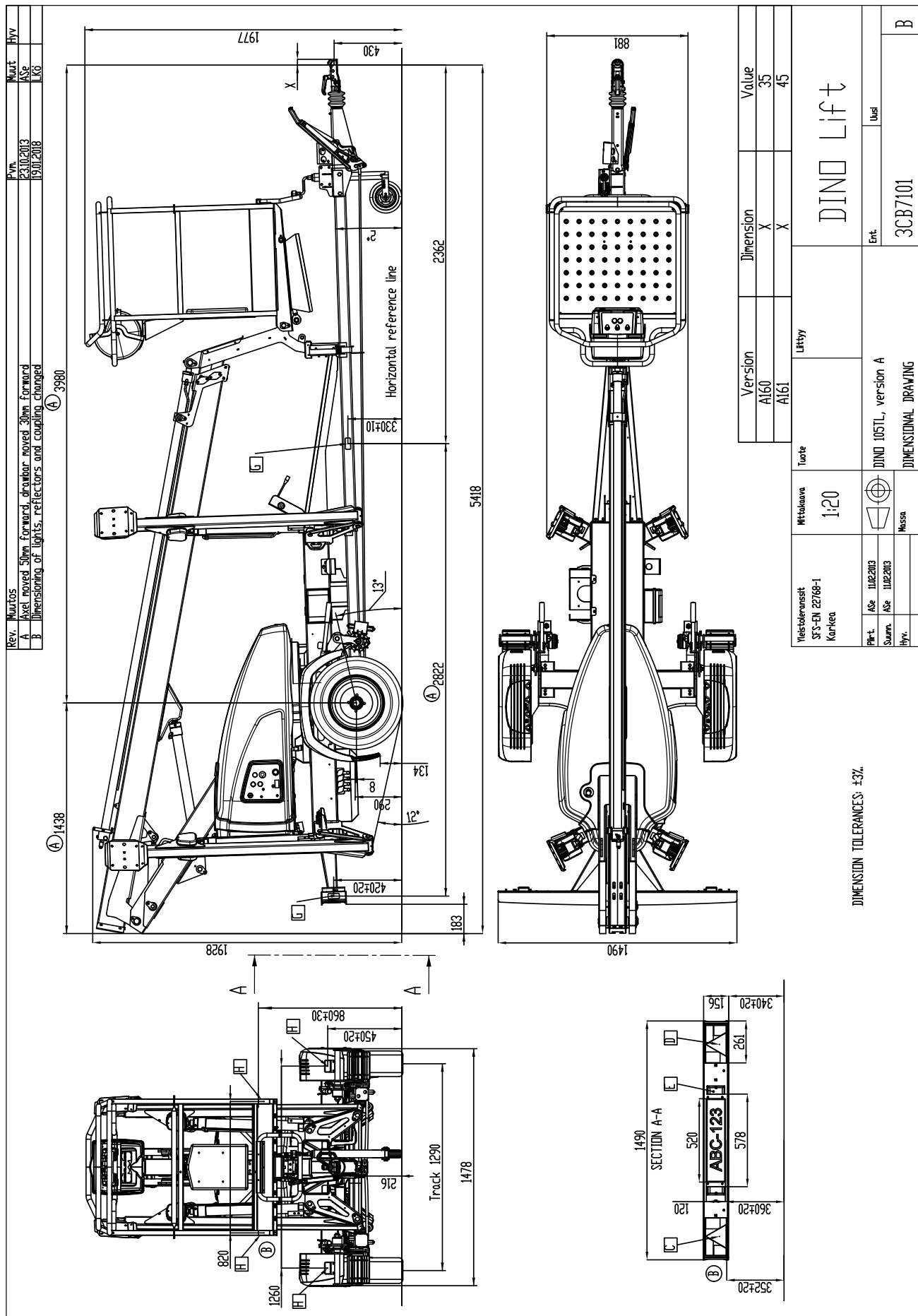

## 2.2. REACH DIAGRAM

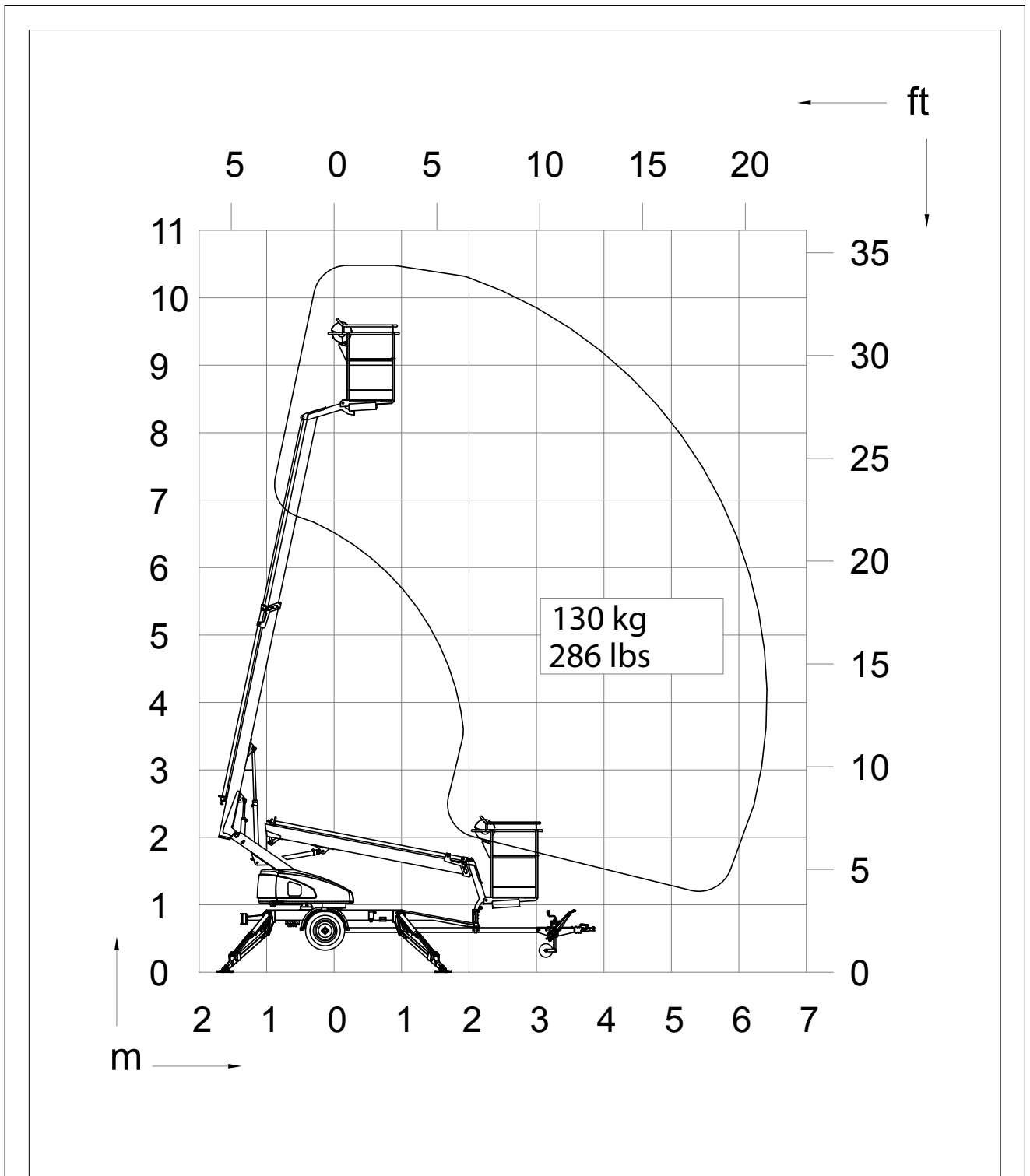

Nro	Piirr.nro	Nimitys		Muoto / Malli	Materiaali	Kpl
Yleistoleranssit SFS-EN 22768-1		Mittakaava	Tuote	Liittyy	<b>DINO Lift®</b>	
Piirt.	08.01.2013		ULOTTUMAKAAVIO		Ent.	Uusi
Suunn.	08.01.2013				DINO 105 TL	
Hyv.		Massa				
		Kg				

### 2.3. EXAMPLE OF THE MACHINE'S NAMEPLATE

The name of the manufacturer, and the production number and serial number of the machine have been marked on the nameplate as shown in the picture below.

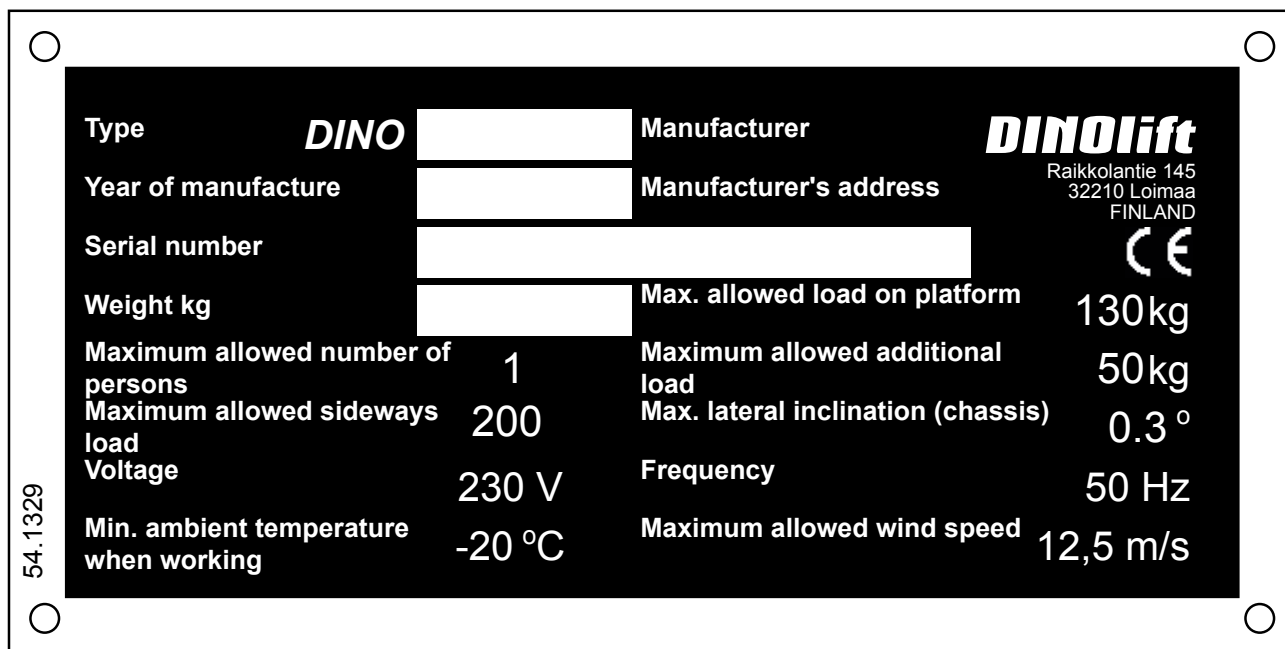

The nameplate of the lift is located on the right-hand side of the chassis, as shown in the picture.

The serial number is also engraved in the lift's chassis, on the upper surface of the right-hand tow-bar.

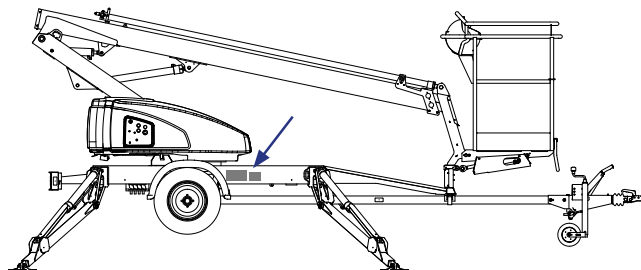

The nameplate of the trailer is located on the chassis, on the right-hand side of the nameplate of the lift.

Following data is written on the plate:

EU Type Approval Number (if available)		
Serial number		
	Total weight	kg
0	Maximum allowed weight on the towing hitch	kg
1	Maximum allowed axle weight	kg
2		kg

**2.4. EXAMPLE OF EU DECLARATION OF CONFORMITY****EU declaration of conformity for machine**

**Manufacturer:**

**Dinolift Oy  
Raikkolantie 145  
FI-32210 Loimaa,**

which has authorised the Chief Engineer Mr. Santtu Siivola, Dinolift Oy, Raikkolantie 145, 32210 Loimaa, FINLAND, to draw up the Technical Construction File,

**declares that**

**DINO 105TL Aerial Work Platform no YGCD105TLH0010277**

complies with the provisions of the Machine Directive **2006/42/EC** and its amendments as well as the national decree (**VNA 400/2008**), through which they have been brought into effect as well as the regulations of the Low Voltage Directive **2000/14/EC** and the EMC Directive **2014/30/EC**.

Notified body no. 0537,

**VTT**  
P.O.Box 1300  
FI-33101 Tampere  
FINLAND

**has granted the certificate no. VTT 182 / 524 / 13**

In designing the machine, the following harmonised standards have been applied:

**SFS-EN 280/A1+A2; SFS-EN 60204-1/A1**

Loimaa                      08.06.2017

-----  
Santtu Siivola  
Chief Engineer

## 2.5. SAMPLE OF INSPECTION PROTOCOL FOR THE ACCESS PLATFORM

### TEST CERTIFICATE

DATE: |

#### START-UP TESTS:

Inspection place: Dinolift Oy

Inspector's signature: \_\_\_\_\_ |

#### BASIC INFORMATION

Manufacturer: Dinolift OY Place of manufacture: Finland

Address: Raikkolantie 145

32210 LOIMAA

Importer: \_\_\_\_\_

Type of lift:  Boom platform       Scissor platform       Mast platform

Chassis:  Car       Self propelled       Trailer mounted       Vehicle mounted (quick coupler)

Boom:  Articulated boom       Telescopic boom       Articulated telescopic boom       Scissor

Fixed mast       Telescopic mast

Load control:  Position control       Limited size of work platform       Moment sensing       Load sensing

Outriggers:  Hydraulic turning       Hydraulic pushing       Mechanical       Stabilized with wheels

#### TECHNICAL SPECIFICATIONS

Machine and type:	<u>DINO 105TL</u>	Max. platform height	<u>8,50 m</u>
Number of manufacture		Max. outreach:	<u>6,50 m</u>
Year of manufacture			
Max. lifting capacity:	<u>130 kg</u>	Boom rotation:	<u>+/- 355°</u>
Max. person number:	<u>1</u>	Support width:	<u>3,25 x 3,3 m</u>
Max. additional load:	<u>50 kg</u>	Transport width:	<u>1,50 m</u>
Power supply:	<u>230 VAC</u>	Transport length:	<u>5,44 m</u>
Lowest temperature:	<u>-20 °C</u>	Transport height:	<u>1,99 m</u>
Weight:	<u>955 kg</u>	Platform size:	<u>0,85 x 0,7 m</u>

INSPECTION POINTS		(Y = meet standards N = do not meet standards)		<input type="checkbox"/> <input type="checkbox"/> not applicable)	
	Y	N		Y	N
<b>A. GENERAL REQUIREMENTS</b>					
1. Suitability for use	<input checked="" type="checkbox"/>	<input type="checkbox"/>			
2. Certificate of conformity	<input checked="" type="checkbox"/>	<input type="checkbox"/>			
3. User manual and storage	<input checked="" type="checkbox"/>	<input type="checkbox"/>			
4. Machine plate - inspection plate	<input checked="" type="checkbox"/>	<input type="checkbox"/>			
5. Instructional and safety plates	<input checked="" type="checkbox"/>	<input type="checkbox"/>			
6. Safety colours	<input checked="" type="checkbox"/>	<input type="checkbox"/>			
<b>B. STABILITY</b>					
1. Load plate and reach diagram	<input checked="" type="checkbox"/>	<input type="checkbox"/>			
2. Supports / outriggers	<input checked="" type="checkbox"/>	<input type="checkbox"/>			
3. Indicator for horizontal position	<input checked="" type="checkbox"/>	<input type="checkbox"/>			
<b>C. STRUCTURES</b>					
1. Transport position / transp. equipment	<input checked="" type="checkbox"/>	<input type="checkbox"/>			
2. Driving/towing equipment	<input checked="" type="checkbox"/>	<input type="checkbox"/>			
3. Chassis	<input checked="" type="checkbox"/>	<input type="checkbox"/>			
4. Turning device	<input checked="" type="checkbox"/>	<input type="checkbox"/>			
5. Boom system	<input checked="" type="checkbox"/>	<input type="checkbox"/>			
6. Structure and position of work platform	<input checked="" type="checkbox"/>	<input type="checkbox"/>			
7. Hydraulic system	<input checked="" type="checkbox"/>	<input type="checkbox"/>			
<b>D. ELECTRIC SYSTEM</b>					
1. Electric system	<input checked="" type="checkbox"/>	<input type="checkbox"/>			
2. Electric appliances	<input checked="" type="checkbox"/>	<input type="checkbox"/>			
3. Lights	<input checked="" type="checkbox"/>	<input type="checkbox"/>			
<b>E. SAFETY AND CONTROL DEVICES</b>					
1. Safety sensors and limit switches	<input checked="" type="checkbox"/>	<input type="checkbox"/>			
2. Sound signal	<input checked="" type="checkbox"/>	<input type="checkbox"/>			
3. Emergency descent system	<input checked="" type="checkbox"/>	<input type="checkbox"/>			
4. Protection of controls	<input checked="" type="checkbox"/>	<input type="checkbox"/>			
5. Symbols / control directions	<input checked="" type="checkbox"/>	<input type="checkbox"/>			
6. Placement of controls	<input checked="" type="checkbox"/>	<input type="checkbox"/>			
7. Emergency stop	<input checked="" type="checkbox"/>	<input type="checkbox"/>			
<b>F. SAFETY FEATURES</b>					
1. Prevention of unauthorized use	<input checked="" type="checkbox"/>	<input type="checkbox"/>			
2. Locking device, covers and guards	<input checked="" type="checkbox"/>	<input type="checkbox"/>			
3. Prevention of lifting	<input checked="" type="checkbox"/>	<input type="checkbox"/>			
4. Prevention of opening of support	<input checked="" type="checkbox"/>	<input type="checkbox"/>			
5. Safety distances	<input checked="" type="checkbox"/>	<input type="checkbox"/>			
6. Control of loading	<input checked="" type="checkbox"/>	<input type="checkbox"/>			
7. Limiting devices	<input checked="" type="checkbox"/>	<input type="checkbox"/>			
<b>G. TEST LOADING</b>					
1. Overload test (150%)			195 kg	<input checked="" type="checkbox"/>	<input type="checkbox"/>
2. Functional test (110%)			145 kg	<input checked="" type="checkbox"/>	<input type="checkbox"/>

**COMMENTS**

**DEFICIENCIES**

---



---



---



---

Deficiencies have been repaired

Date: \_\_\_\_\_ Signature: \_\_\_\_\_

The initial inspection and test loading of the Dino aerial work platforms is performed by the manufacturer. A protocol, drawn up during the inspection, will accompany the lift.

The protocols of the start-up and periodic inspections must be kept with the lift or its immediate proximity for at least five years.

### 3. SAFETY

All the essential safety instructions and warnings, relevant to transport, use and maintenance of the lift, are described in this chapter.



## DANGER

Failure to observe these instructions and safety regulations may cause a severe injury or even death. Familiarise yourself with all the safety regulations, operating instructions and signs affixed to the machine, and follow them.

Make sure that you understand all the safety instructions and regulations. Also make sure that others operating the machine or working on the work platform are familiar with these instructions.

#### 3.1. SAFETY INSTRUCTIONS

Only specially trained personnel with authorisation in writing, who are well familiarised with the device, and at least 18-years old, are allowed to operate the unit.

Keep the lift free of any dirt, which may impair safe operation, and impede the inspection of the structures.

The device must be serviced and inspected regularly.

Only skilled persons, familiar with the service and repair instructions for the lift, are allowed to carry out servicing and repair work.

It is strictly prohibited to use a lift which is out of order.

Never remove or disable any safety devices of the machine.



## WARNING

The device must neither be altered without the manufacturer's consent nor be used under conditions, which do not meet the manufacturer's requirements.

The operator must be given instructions and consent from the manufacturer for all such specific work methods or conditions that the manufacturer has not explicitly defined.



## TRANSFERS

Observe the maximum allowed gradient when transferring the lift. During transfer in rough terrain, always try to position yourself higher than the machine.

Beware of fixed or moving obstacles in the terrain or near the lift while driving. Make sure that you have a clear view of the driving path.

Do not use the machine for towing.

## WORK AREA AND PREPARATIONS BEFORE LIFTING WORK

When working in busy areas, the operating range of the lift must be clearly marked by using either warning lights or fencing.

Also observe the road traffic regulations.

Ensure the unobstructed range of movement before operating the stabilisers.

The load-bearing capacity and the gradient of the base must be taken into account when supporting the chassis. Do not operate the machine while it is placed on a truck, railway car, floating vessel or other possibly unstable structures.

Ensure that the stabilisers cannot slide while on a gradient.

Additional support plates of adequate size must be used under the stabilisers, when working on soft ground. Only use such additional support plates, on which the metallic stabilisers will not slide.

While in the support position, ensure that the wheels are off the ground.

Always verify the horizontal position of the machine before operation.

Always ensure that the work area is clear of outsiders. Danger of getting crushed between rotating and fixed structures.

**While operating the boom from the control centre on the turning device, beware of getting pressed against the stabilisers or other structures that do not turn with the boom.**

## LIFTING AND WORKING ON THE PLATFORM

Never exceed the maximum number of persons, maximal loading or manual force, allowed for the lift. Never add load onto the platform while in the upper position.

Before operating, always ensure that the safety devices and the emergency descent system are in working order.

**Use the safety harness!** Fix the safety harness to the fixing points, intended for the purpose.

Note! The platform is fitted with a fixing point for the safety harness of each user. Only one harness per fixing point.

Do not use ladders, steps or other similar equipment on the platform.

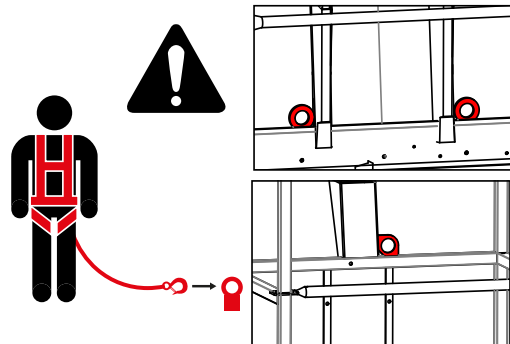

Before operating the machine, make sure all gates are properly closed.  
If the platform is fitted with a ladder, the ladder must be locked in the upper position.

Never throw or drop any objects from the platform. All tools must be carried inside the work platform. Never leave power tools hanging by the cord outside the work platform.

Do not carry tools, equipment or materials on or attached to the platform railing.

The lift must not be used as a crane.  
The lift must not be used for transferring goods or persons between different floors or working levels. Stepping on or off the platform in motion is prohibited.

When the boom is in its lowest positions, make sure it cannot clash during rotation with structures that do not turn with the boom.

Always make sure, before lowering the platform, that the area under it is clear.

Avoid damaging the platform by lowering it on the ground, or bringing it in contact with any structures.

Never use a lift alone. Make sure that there is always someone on the ground, who can call for help in case of an emergency.

## OPERATING CONDITIONS

The weather conditions, such as wind, visibility and rain, must always be taken into account so that these will not adversely affect the safe performance of the lifting operations.



**The use of the lift is prohibited, if the temperature drops under -20 °C or the wind speed exceeds 12.5 m/s**

Wind speed ( m/s)		Conditions on land
0	Calm	Smoke rises vertically
1-3	Light breeze	Smoke moves with the wind and the wind feels on exposed skin. Leaves rustle.
4-7	Moderate breeze	Leaves and small branches of trees are moving. Flag is flying. Wind lifts dust and loose pieces of paper from the ground.
8-13	Strong breeze	Small broad-leaved trees and large branches sway. Wind whistles as it hits houses or other fixed objects. Umbrella is difficult to use.
14-17	Moderate gale	All the trees are swaying. It is difficult to walk against the wind.

NOTICE! Wind speed can be significantly greater at height than at ground level.

Do not take tools/material of large surface area onto the platform. The increase in wind load may jeopardize the stability of the device.

**Beware of the live aerial power lines in the area – observe the minimum safety distances:**

Voltage area (from phase to phase)	Minimum distance	
	Metres	Feet
0–300 V	Avoid contact	
300 V–50 kV	3	10
50 kV–200 kV	4.5	15
200 kV–350 kV	6	20
350 kV–500 kV	8	25
500 kV–750 kV	11	35
750 kV–1000 kV	14	45

Observe these distances, if the worksite-specific instructions or the local or national regulations do not require even longer safety distances.

This aerial work platform is NOT insulated, and does not offer protection against contact with electric current. The aerial work platform must not be used for work on electric systems.

### 3.2. SAFETY-RELATED NOTIFICATIONS

The following safety alert symbols and safety signal words are used in this manual.

Observe all the safety instructions that follow these symbols, in order to avoid dangerous situations and personal injuries.



This is a general safety alert symbol and it is used to alert you about a potential hazard. Observe the additional instructions given in form of text or symbols that follow this symbol.



## DANGER

Red DANGER-message warns for an imminent or potential hazardous situation which, if not avoided, may result in death or serious injury.



## WARNING

Orange WARNING -message is used in connection with potential risk factors, which if not avoided, under certain conditions, may result in death or serious injury.



## CAUTION

Yellow CAUTION -message is used to warn about a hazardous situation which, if not avoided, could result in minor or moderate injury.

## NOTICE

Blue notice-message is used to draw your attention to special notifications or instructions that are related to the operation or maintenance. Such messages include, for example, instructions that are related to reliability of the machine or aim to avoid material losses.



Risk of getting crushed  
- moving parts



Risk of getting crushed  
- moving parts



Risk of getting crushed  
- falling objects



Harmful exhaust gas  
emissions

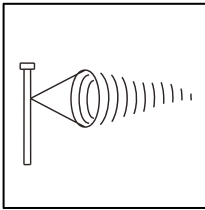

Wind speed

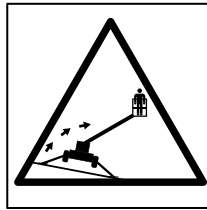

Risk of turning over

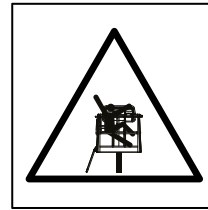

Risk of falling

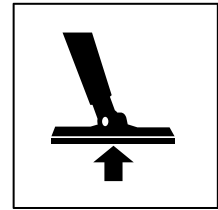

Support force



Smoking prohibited

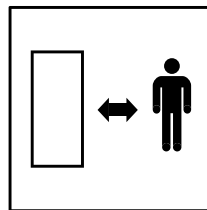

Keep safe distance

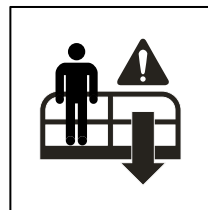

Emergency descent

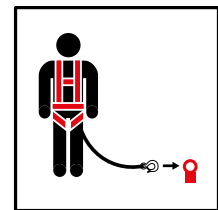

Fixing point for the  
falling guard



Open flame prohibited

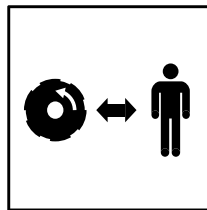

Keep safe distance

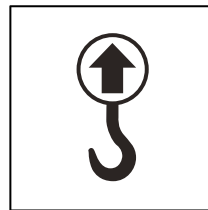

Lifting point

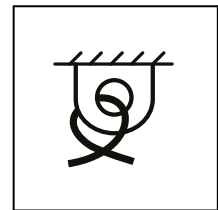

Fixing point



Running the engine  
indoors prohibited

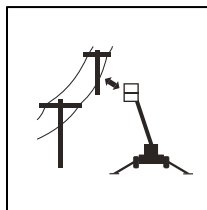

Keep safe distance to  
the power lines

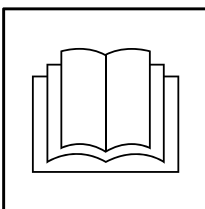

Operating instructions

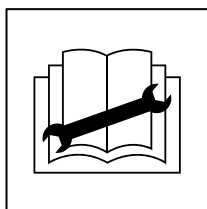

Maintenance  
instructions

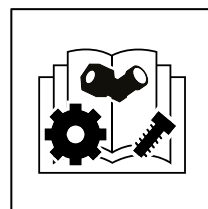

Spare parts catalog

### 3.3. SAFETY DEVICES

#### 1. Supervision of transport position of the boom

The safety limit switch RK3 prevents the operation of the outriggers and the driving device when the boom is not resting on the transport support. The switch is located on the tow-bar at the transport support.

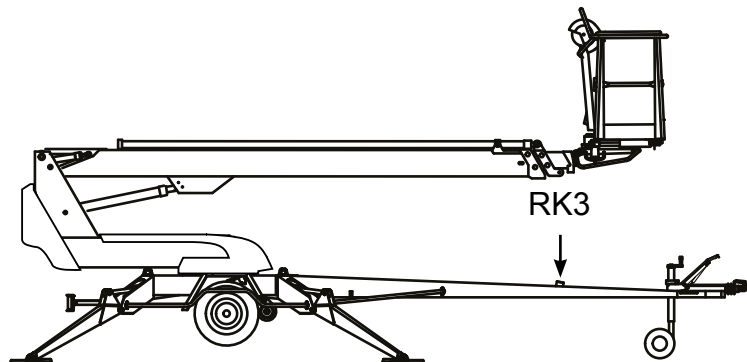

#### 2. Supervision of supporting

The lift's all support outriggers must be in the support position before the boom is lifted. Make sure that the wheels are off the ground.

The safety limit switches RK11, RK12, RK13 and RK14 are located on the support outriggers.

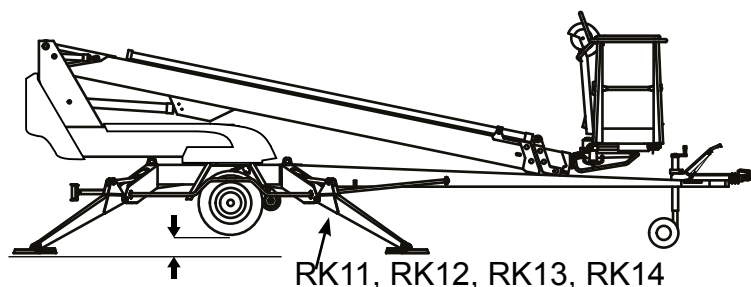

#### 3. Preventing the inclination of the platform

The platform is levelled hydraulically by means of a so-called slave cylinder system, where the master cylinder controls the slave cylinder that inclines the work platform.

The levelling system comprises the following parts:

1. Master cylinder
2. Slave cylinder
3. Load regulation valve
4. Double load regulation valve
5. Electric directional valve

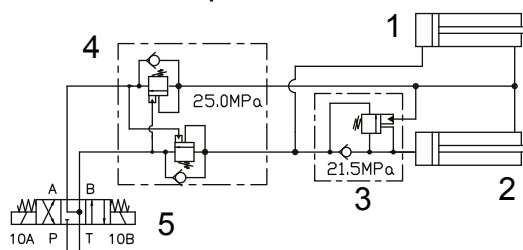

## 6. Safety devices for hose rupture

All the load-bearing cylinders are equipped with valves for rupture or leak in the hydraulic system, which prevent the load from falling.

Outrigger cylinders	Lock valves	Prevent the inching of the outriggers in either direction.
Lifting cylinder of the boom	Load regulation valve	Prevents the load from falling
Telescope cylinder	Load regulation valve	Prevents the inching of the telescope in either direction.
Levelling system	Load-holding valves	Prevents the inclination of the platform in either direction.

## 7. Emergency stop buttons

Depressing the emergency stop button, stops all the movements immediately and turns off the power unit. The button can be found at each control station. Once the button has been depressed, only the emergency descent functions remain operational.

The emergency stop button locks in the lower position, and it must be released before starting the power unit.

### **NOTICE**

If the unit does not start, make sure that the emergency descent button is not in the lower position at any of the control stations.

## 4. STRUCTURE AND FUNCTIONS OF THE LIFT

The denominations of the machine's essential parts and concepts, which are used later in these instructions, are described on the following pages.

### 4.1. STRUCTURE OF THE LIFT

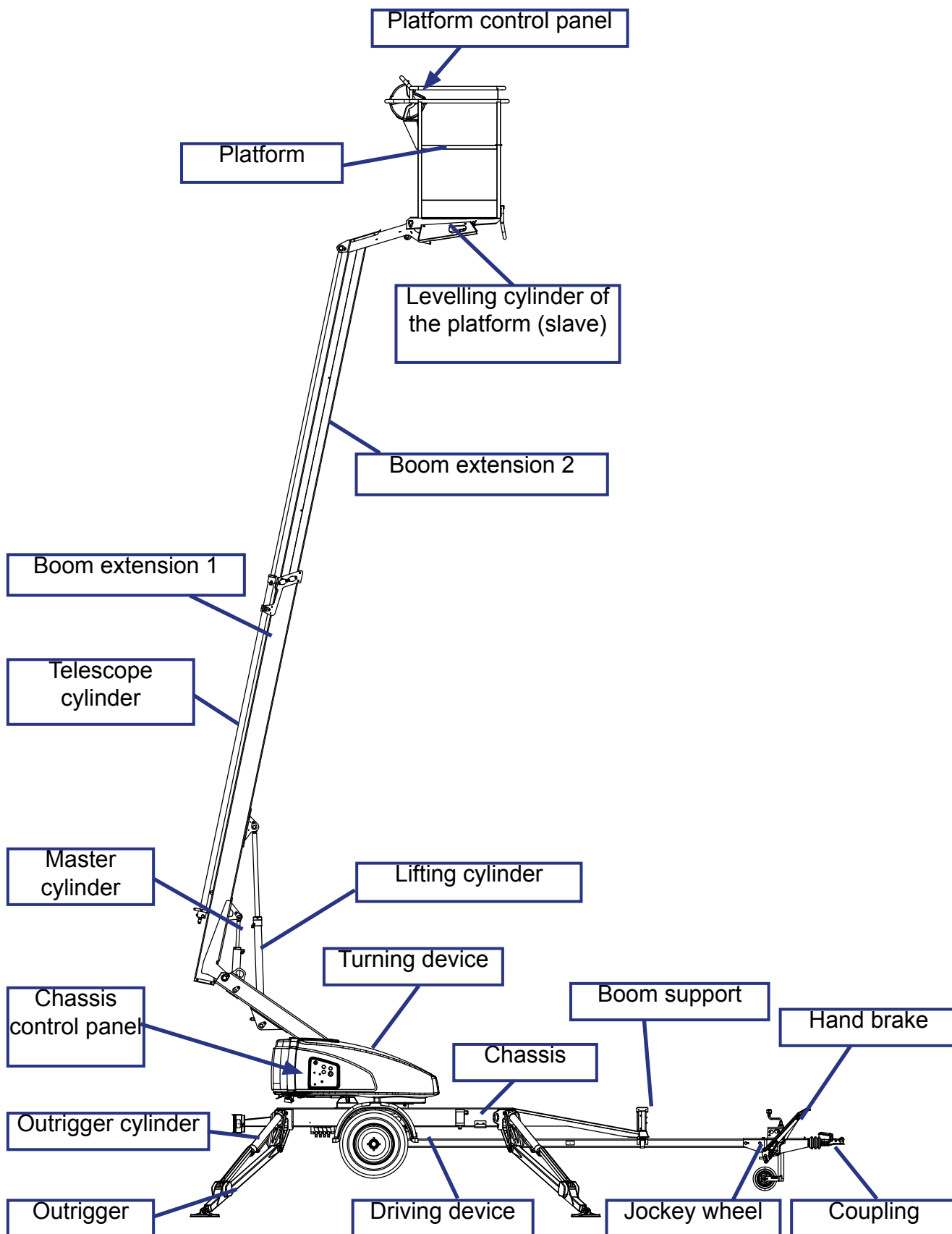



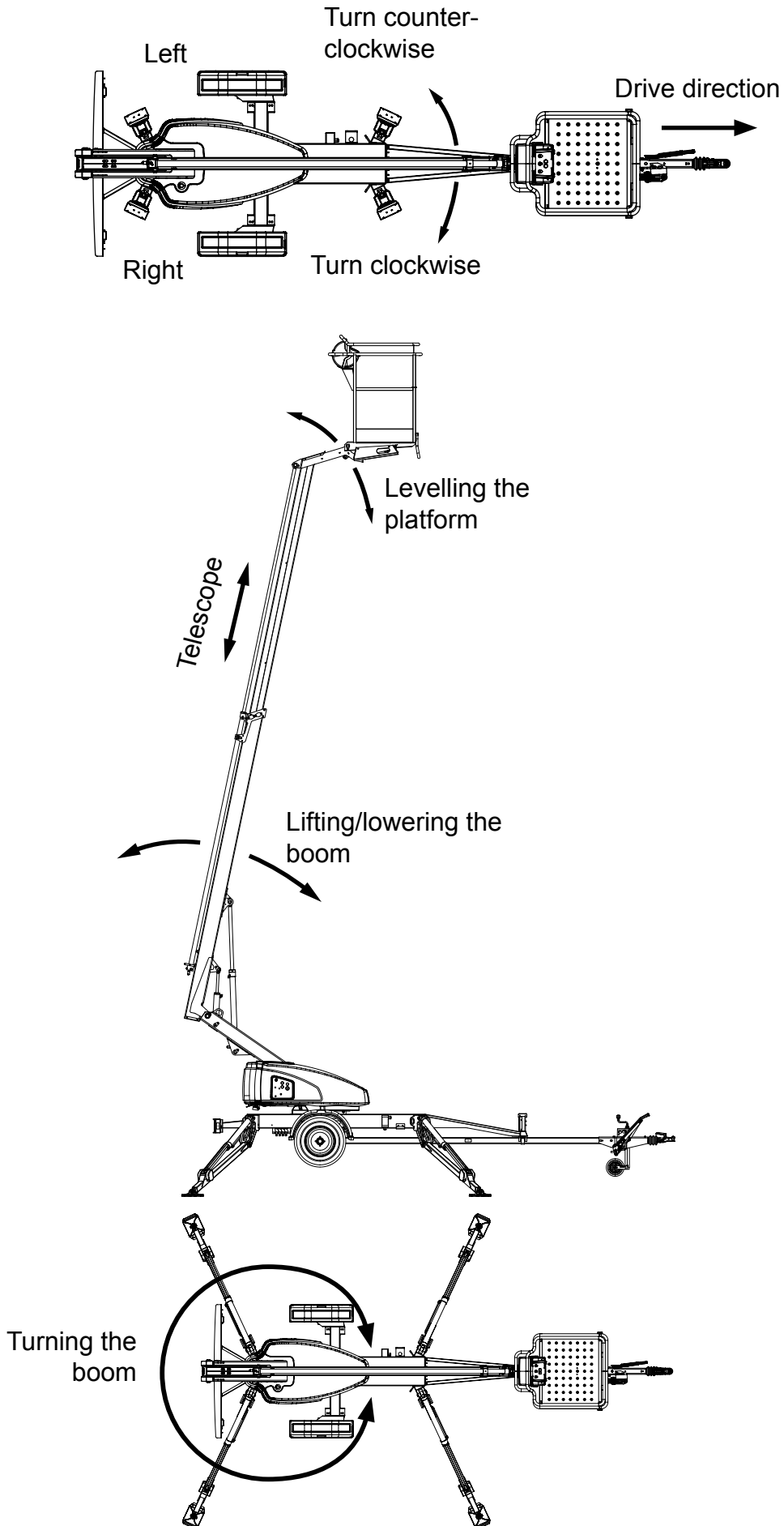

## 4.2. FUNCTIONS OF THE WORK PLATFORM



### 4.3. OPERATING CONTROLS FOR THE FUNCTIONS

#### 4.3.1. Operating controls in the chassis control centre

Q1	Selector switch	S2	Slow speed
OFF	Ignition off	S3	High speed
	Operating controls in the chassis control centre LCB.	S16	Lever switch for turning of the boom system
	Operating the lift from the platform control centre UCB	S17	Lever switch for lifting of the boom system
S1	Emergency stop	S18	Lever switch for telescope
Vi	Signal light: voltage supply connected	S20	Lever switch for levelling the platform
H3	Signal light for the outrigger limit switches		

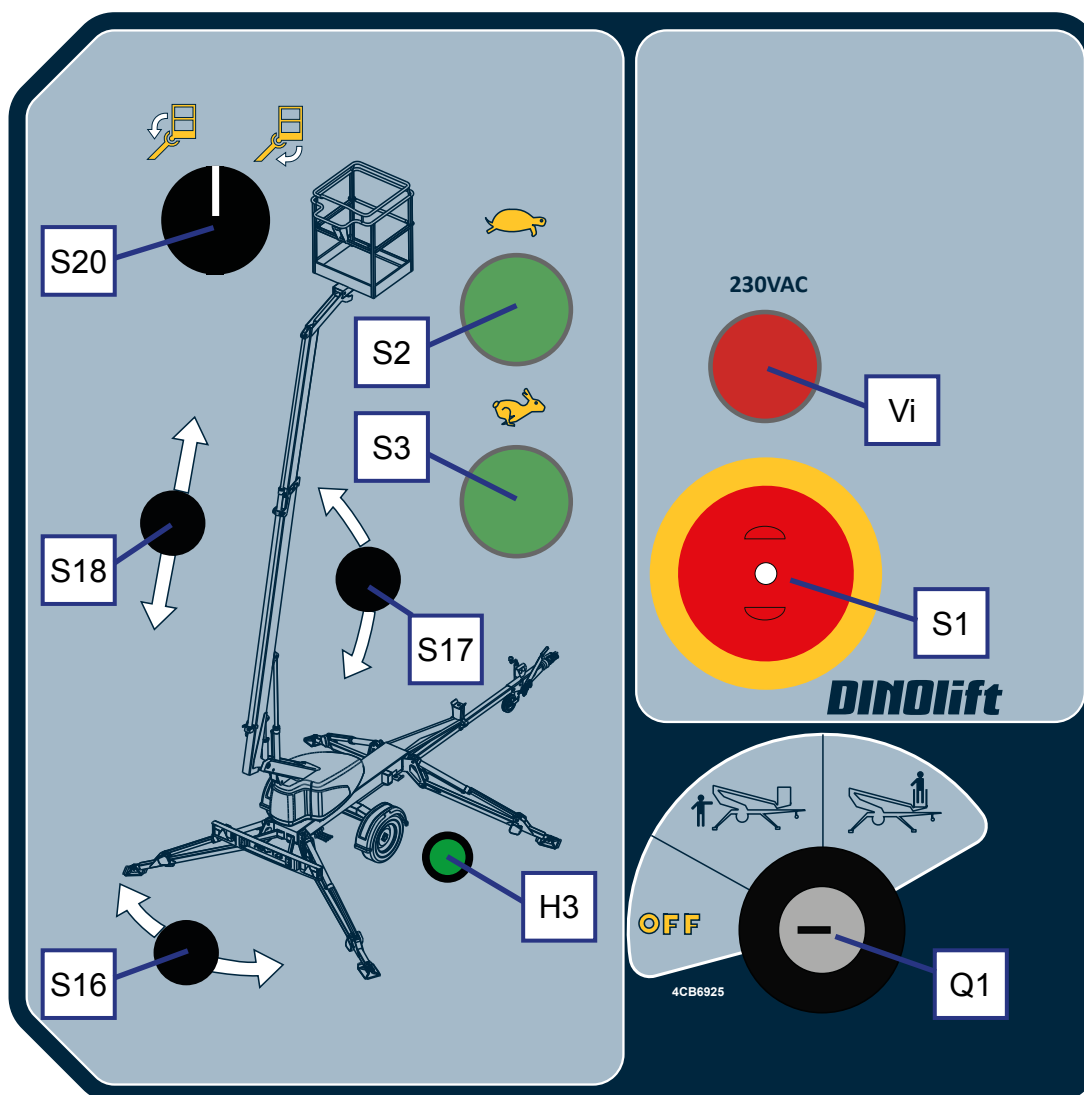

## 4.3.2. Operating controls for the outriggers

1	Rear outrigger, right
2	Rear outrigger, left
3	Front outrigger, left
4	Front outrigger, right
5	Position indicator of chassis

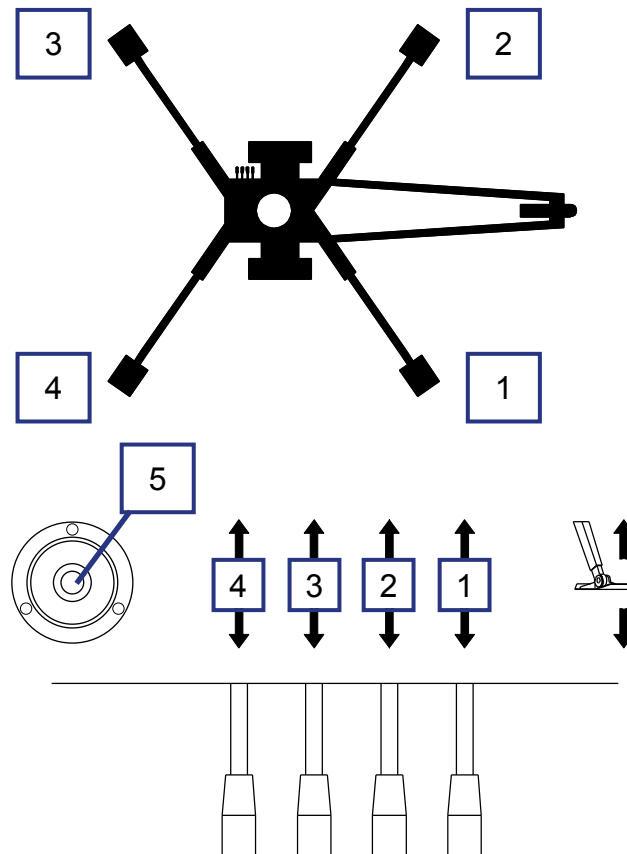

### 4.3.3. Operating controls in the platform control centre

Remove the key from the selector switch Q1 before starting the operation of the lift from the platform control centre UCB.

S4	Emergency stop	S8	Lever switch for lifting of the boom system
S5	Slow speed	S9	Lever switch for telescope
S6	High speed	S10	Sound signal button
S7	Lever switch for turning of the boom system	S12	Lever switch for levelling the platform

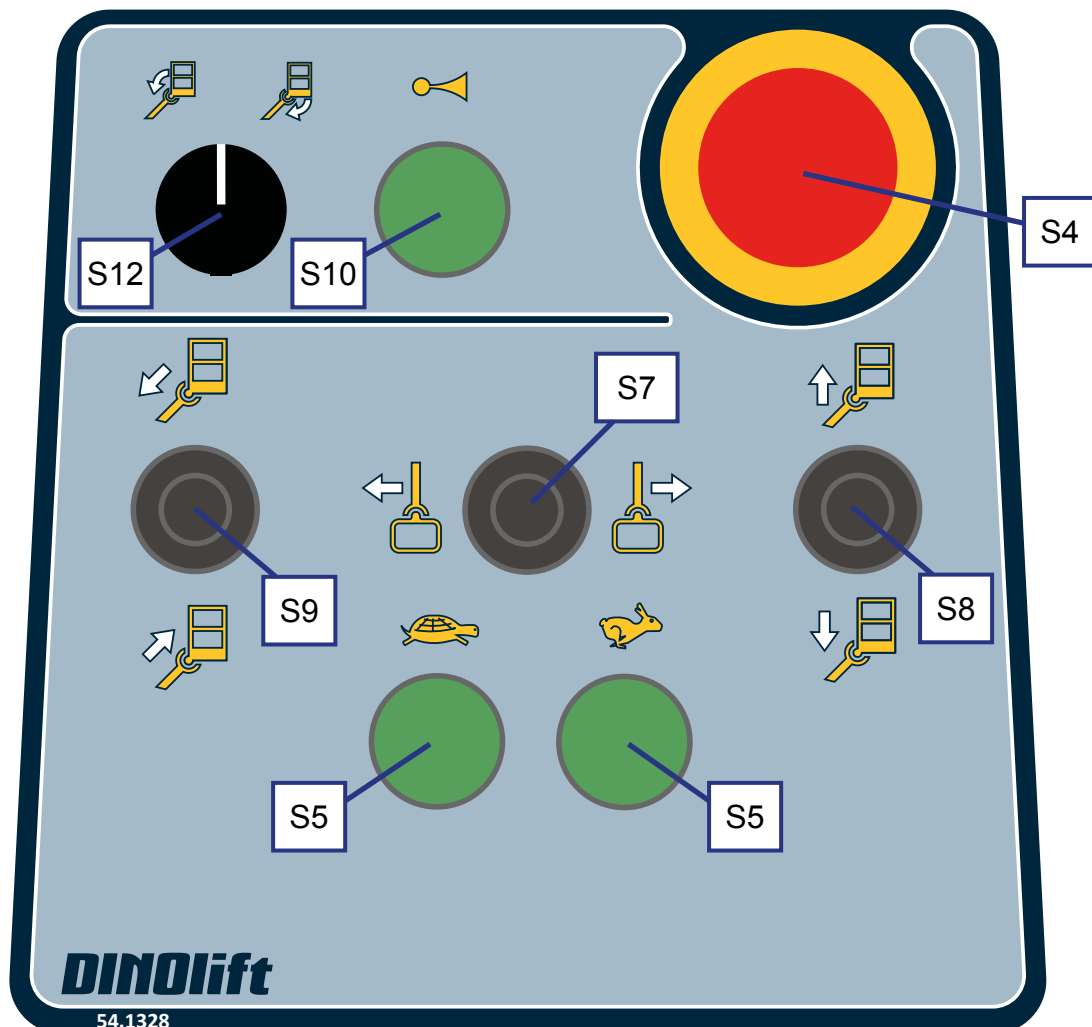

## 5. OPERATING INSTRUCTIONS

### 5.1. START-UP

#### **NOTICE**

Before operating the lift, perform all daily maintenance measures listed in the maintenance schedule.

The operator must do a worksite inspection and daily maintenance:

- at the beginning of each workday
- before operating the lift at a new worksite
- when the operator changes in the middle of a workday

#### 5.1.1. Worksite inspection

##### 1. General information

- Is the lift suited for the intended job?
- Is the performance of the lift sufficient for the job? (reach, loadability etc.)
- Is the position of the lift safe?
- Is the lighting on the worksite sufficient?

##### 2. Documents

- Are the Operation and Service Instructions for this lift present? (Manufacturer's instructions)
- Are inspections and servicing carried out in accordance with the instructions and have the defects affecting the safety been checked as repaired?
- (Inspection protocols)

##### 3. Structure (Visual inspection and operational test)

- General condition of the lift
- Operation and protection of the controls
- Emergency stop, signal horn and limit switches
- Electrical appliances and wiring
- Oil leaks
- Load markings and signs

##### 4. Operator

- Is the operator old enough?
- Has the operator received the required training?

##### 5. Special issues on the worksite

- Are there any additional regulations relevant to the worksite or the work?

### 5.1.2. Positioning the lift

1. make sure that the ground is even and hard enough to support the lift in a steady, level position.

Soil material	Density	Max. ground pressure	
		P	kg/cm <sup>2</sup> (N/cm <sup>2</sup> )
Gravel	High density		6 (59)
	Medium density		4 (39)
	Loose		2 (20)
Sand	High density		5 (49)
	Medium density		3 (29)
	Loose		1,5 (15)
Fine sand	High density		4 (39)
	Medium density		2 (20)
	Loose		1 (10)
Sand / mud	High density (very hard to work)		1,00 (10)
	Medium density (hard to work)		0,50 (5)
	Loose (easily worked)		0,25 (3)

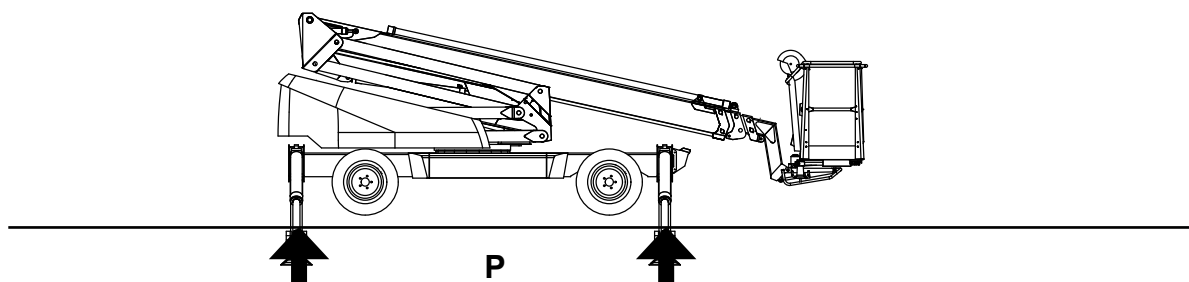

DANGER

If the ground is soft, use sufficiently large and sturdy additional plates under the support outriggers.

2. Drive the lift to the inspected lifting site
3. Engage the parking brake
4. Disconnect the lift from the towing vehicle

## 5.1.3. Starting up

To access the operating controls, open the cover of LCB centre on the turning device.

1. Switch on the current for the lift
  - connect the mains cable to the power supply
  - with the electric motor at maximum load, the voltage must be 230 VAC (-10%/ +6%), the frequency 50 Hz, and rating of the fuse 10A (the length of the connecting cable has some effect)
2. Turn the selector switch Q1 to position LCB – chassis control centre. 
3. Start the engine using either of the speed selector switches

## 5.1.4. Supporting the lift

1. Lower the front outriggers (on the tow-bar side).
2. Lower the outriggers in the rear. (do not damage the tow-bar jockey wheel).
3. Level the chassis using the outriggers in accordance with the level gauge. The air bubble must be located inside the inner ring.
4. The green signal light in the chassis control centre LCB is illuminated, when all the outriggers are in the support position and the limit switch circuit of the outriggers is closed.

### Before using the lift, always check that:

- the chassis is in the horizontal position, in accordance with the position indicator
- the wheels are off the ground
- the outriggers are firmly supported on the ground, and the limit switch circuit of the outriggers is closed (green LED in the chassis control centre is illuminated)



## DANGER

**The operation is prohibited, if the lift is not properly supported and in a horizontal position.**

**Observe the effect of ice, possible rain and inclination of the surface on the support (the support outriggers must not slip on the surface).**

## 5.2. OPERATION



### WARNING

Carry out all the daily maintenance routines and inspections in accordance with the maintenance instructions before operating the lift. **Failure to check the safety devices may cause a serious injury or make the consequences of an accident worse.**

#### 5.2.1. Operating the lift from the chassis control centre

1. Turn the selector switch Q1 to the position LCB – chassis control centre.
2. Select the desired movement speed by depressing the speed selector switch. Drive the boom and the platform using the control levers in the chassis control centre:

- extending and retracting the telescope
- lifting and lowering the boom
- turning the boom

The movement will stop if either the control lever for the movement or the speed selector switch is released.

3. Before starting the operation, lift the platform from the tow-bar and turn it to the side so that you can lower the boom.
4. Extend the telescope as much as is necessary to ensure that stepping onto the platform is safe.

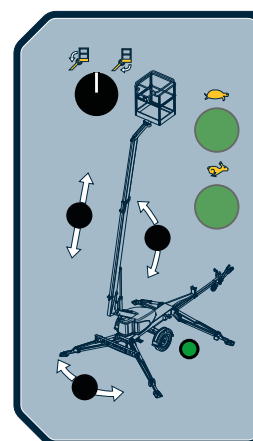

### NOTICE

Do not damage the tow-bar jockey wheel!

#### Adjusting the position of the platform from the chassis control centre:

The levelling system of the platform will automatically keep the platform level during the movements. As necessary, the position can be corrected.

Carry out the levelling of the platform while the lift is in the support position (the outriggers in the lower position). Adjust the position of the platform with the boom in the level position. No persons allowed on the platform during the adjustment.

The position of the platform may be adjusted from the chassis control centre in the following way:

1. Turn the selector switch Q1 to the position LCB.
2. Depress the speed selector switch
3. Select the desired direction of the correction movement using the control lever (9).

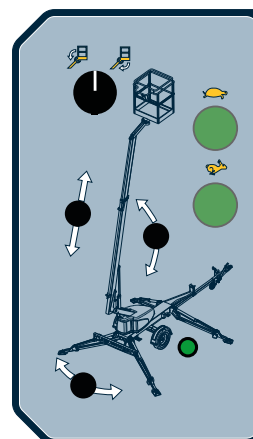



## 5.2.2. Operating the lift from the platform control centre

1. Turn the selector switch to the position "Platform control centre UCB", and remove the key. Do not lock the protective cover for the chassis control centre.
2. Step onto the platform and fix the safety harness to the intended attachment point.
3. Start using the lift normally. Operate the movements of the boom and the platform as follows:

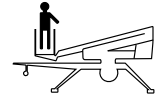

	<p>Select the movement speed using one of the speed selector switches. Selecting the movement speed will start the engine automatically.</p>
	<p>Operate the boom using the control lever. Whenever possible, keep the boom short while lifting and lowering the platform.</p>
	<p>If necessary, operate the levelling system for the work platform by depressing the speed selector switch and using the lever switch.</p>
<p>Note! The movements of the boom and the platform will stop as soon as the speed selector switch or the selector switch for the movement is released. Selecting the movement speed will start the engine automatically.</p>	

4. With the boom slightly lifted and the telescope extended, make sure that the platform does not lower by itself while the operating controls are not being used.
5. Drive the platform to the work object.

## CAUTION

The lift itself, the buildings around it and other obstructions constitute a risk of getting squeezed. Hands and legs must be kept inside the work platform while the platform is moving. Also beware of any obstacles above the platform.

**IF THE SAFETY DEVICES OR THE EMERGENCY DESCENT SYSTEM ARE NOT WORKING, HAVE THEM REPAIRED BEFORE OPERATING THE LIFT.**

If several control levers are operated simultaneously, only the movement with the least resistance will operate.

### Working a long time in the same position

- During cold weather, the power pack must be left running to keep the hydraulic oil warm.
- Check the stability and condition of the base regularly during the operation, taking into account the weather and ground conditions.

### When moving the platform, remember the following

- beware of high voltage power lines
- do not touch open electric wires
- do not throw objects from the platform
- do not damage the lift
- do not damage other devices



## DANGER

**It is strictly prohibited to take additional load in the upper position.**

Do not exceed the lateral force (200N), or load the platform in the vertical direction more than allowed.

Lowering the platform to transport position:

Always retract the telescope completely and turn the platform perpendicular to the boom before lowering the boom onto the transport support.

## NOTICE

Do not damage the tow-bar jockey wheel while lowering the platform to the transport position!

### When leaving the lift

- drive the lift to a safe position, preferably to the transport position
- switch off the power unit
- prevent unauthorized use of the lift by locking the control centre cover

### 5.2.3. Special instructions for winter use

**The lowest allowed operating temperature of the lift is -20 °C**

In cold conditions, carry out the following special actions in addition to the normal start-up procedure:

1. Let the power pack run for a few minutes before starting the movements.
2. To ensure the proper operation of the valves, do first a few warm-up movements to change warm oil in the cylinders.
3. Check that the limit switches and the emergency descent devices are operational and clean (from dirt, snow, ice, etc.).
4. Protect the control centre and the platform from snow and ice whenever they are not in use.



**Always keep the lift free from dirt, snow etc.**

### 5.2.4. Ending the work

At the end of the workday:

1. Retract the telescopic boom fully.
2. Lower the boom/platform onto the support on the tow-bar. The limit switch on the transport support prevents the operation of the support outriggers if the platform is not down.
3. Close the control centre cover on the work platform.
4. Turn the selector switch to position OFF, and turn off the main switch.
5. Disconnect the lift from the power supply.
6. Always take the selector switch key with you, when you leave the lift.
7. Make sure that the covers are locked.

### 5.3. TRANSFERRING THE LIFT

The lift can be transferred by towing or using its own driving device (option).



**The lift may only be moved in the transport position. No persons or load are allowed on the platform during the transportation.**

#### 5.3.1. Preparing the lift for transport

During transfer, the lift must always be in the transport position.

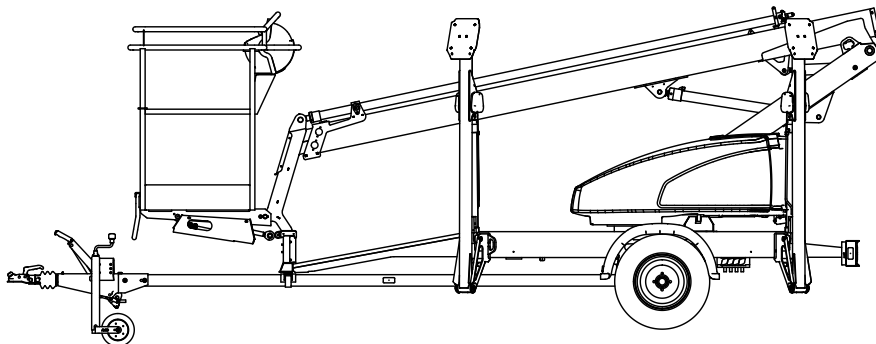

Prepare the lift for the transfer as follows:

1. Retract the telescopic boom fully.
2. Lower the boom/platform onto the support on the tow-bar. The limit switch on the transport support prevents the operation of the support outriggers if the platform is not down.
3. Close the control centre cover on the work platform.
4. Lift the support outriggers.  
Lift first the rear support outriggers (do not damage the rear lights), and then the front support outriggers (do not damage the jockey wheel).
5. Make sure that the covers are locked.

If you intend to tow the lift:

6. Apply the parking brake.
7. Make sure that the driving device is disconnected.
8. Turn the selector switch to position OFF and disconnect the lift from the power supply.

## 5.3.2. Using the driving device

The hydraulic driving device is intended for moving the lift within the work area if the towing vehicle cannot be used.



**During transfer in rough terrain, always try to position yourself higher than the machine.**

1. Turn the selector switch 1 to position “LCB”.
2. Make sure that the platform is in the transport position and the outriggers have been lifted to the upper position.
3. Make sure that the mains cable is long enough to cover the whole travel distance
4. Press the driving devices against the wheels on both sides.
5. Release the parking brake
6. Drive the unit by turning the levers of the manual directional valve in the desired driving direction. Use the right-hand lever to drive the right wheel, and the left-hand lever to drive the left wheel.

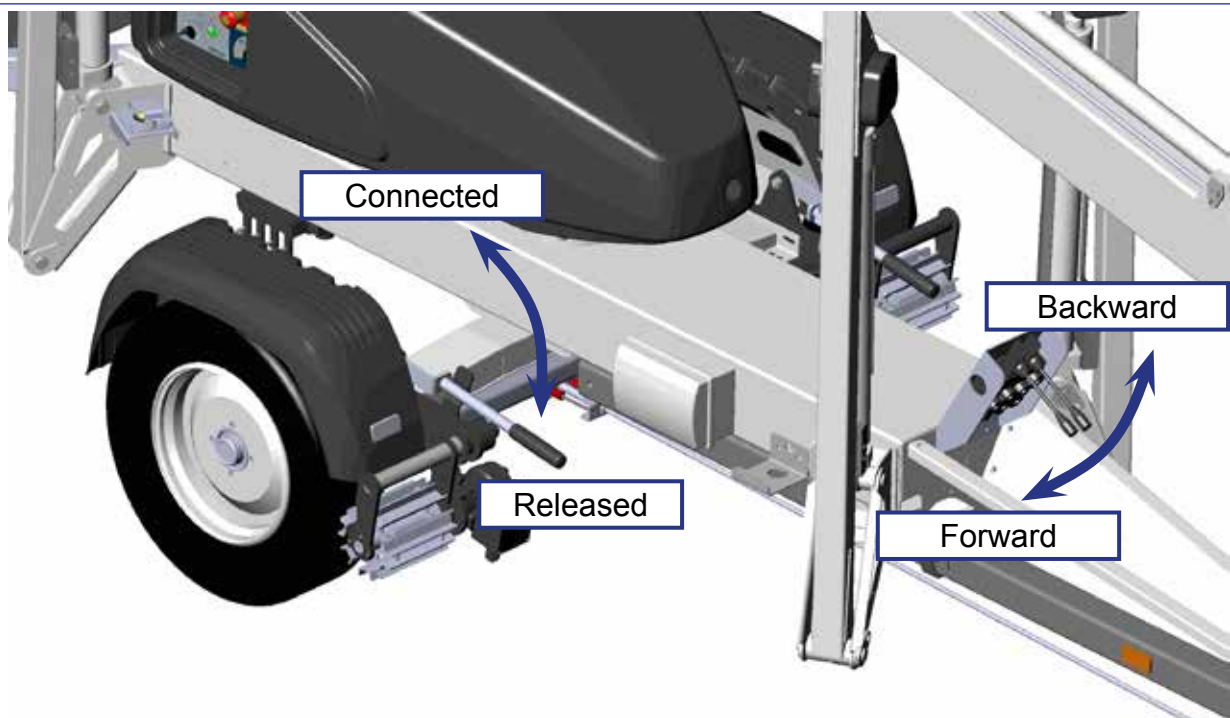

## CAUTION

**Do not drive the jockey wheel into obstacles or potholes.** If one of the wheels bumps into an obstacle, the lift may turn abruptly.

After the driving:

- Apply the parking brake.
- Disconnect the driving devices from the tyres.

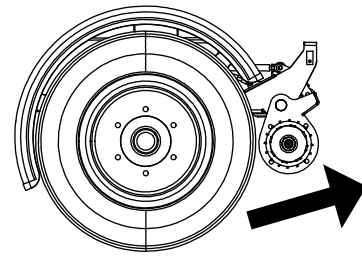

## NOTICE

**Be careful not to damage the jockey wheel tube by extending it too much.**

When moving the lift using the driving device, a suitable length for the jockey wheel's stem can be achieved by adjusting the gap between the lower surface of the tow-bar/brake rod and the wheel to 1-3 cm. Then the wheel may turn freely.

### On a slope:

1. When driving on a slope, the tow-bar must always point towards the descent. Never drive with the driving device with the tow-bar pointing towards the ascent.
2. Always place chocks under the wheels before disconnecting the device from the towing vehicle.
3. Always apply the handbrake before disconnecting the lift from the towing vehicle.
4. Only use the handbrake as a parking brake or for emergency stopping.
5. When transferring the lift using the driving device:
  - take care not to allow the wheel to roll over your foot
  - look out for sudden sideways movements of the tow-bar
  - be careful not to cause danger to other people and the environment
6. Do not move the device on a slope using only hand-power. You may lose control over it and cause an injury.
7. Never park a vehicle combination on a slope.  
Never leave the lift on a slope being supported only by the self-braking action of the driving device.

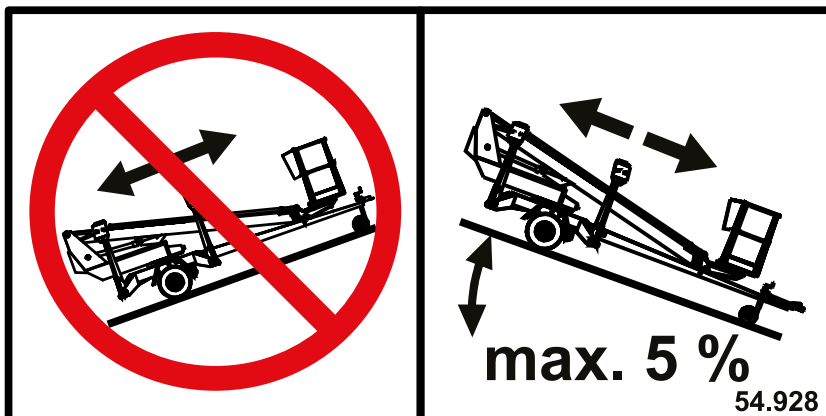

**Do not drive downhill with the driving device, if the inclination of the surface is more than 5 per cent, (corresponding to a descent of 0.5 m over a distance of 10 m). If the gradient of the surface is greater than this, you may lose control of the device.**

### 5.3.3. Towing the lift

Connecting to the towing vehicle

1. Lift up and push forward (in the driving direction) the handle of the ball-coupling. Now the ball-coupling is released.
2. Press the ball-coupling onto the towball using only a little force. The connection and locking take place automatically.



**Always make sure, after the connection, that the ball-coupling is properly locked.**

3. Connect the emergency stop wires and light plug to the vehicle. Check the cable for chafing and proper operation of the wires.
4. Check the operation of the lights.
5. Carefully release the parking brake and make sure that its locking is in order and that its handle stays in the lower position.
6. Lift up the jockey wheel to the transport position.



**Clean and lubricate the ball-coupling regularly.**

In particular, if you are parking or disconnecting the lift from the towing vehicle on a slope, apply the parking brake as firmly as possible. After having applied the parking brake, push the lift backward to make the reverse automatics release the brake shoes. The spring cylinder pulls the parking brake tighter, and the brakes of the vehicle will again be properly engaged.

Adjust the brakes according to the service instructions.

Place chocks under the wheels as an additional precaution.

## NOTICE

Observe the national traffic regulations, the local and worksite-specific instructions, as well as the instructions concerning the towing vehicle.

### **Always ensure before towing:**

- transport position of the outriggers
- locking of the ball-coupling
- operation of the lights, connection of the cable
- that the parking brake is disengaged
- condition and pressure of the tyres The correct pressure ratings are marked on the tyres.
- attachment of the safety wire
- locking of the brakes after the transportation
- locking of the jockey wheel in its upper position
- that the driving device is disconnected from the wheel
- that there is no load on the platform



**Always use chocks under the wheels when disconnecting the lift from the car.**

### 5.3.4. Lifting the device

The device can be lifted using the lugs shown in the picture. The lifting lugs are located symmetrically on both sides of the lift.

During lifting the aerial work platform must be in the transport position. Remove all loose material from the top of the frame structures and the work platform before lifting.

Use for lifting a suitable crane with sufficient capacity and relevant accessories. Check the weight of the lift in the technical specifications.



**Be careful not to damage the unit during the lifting operation.**

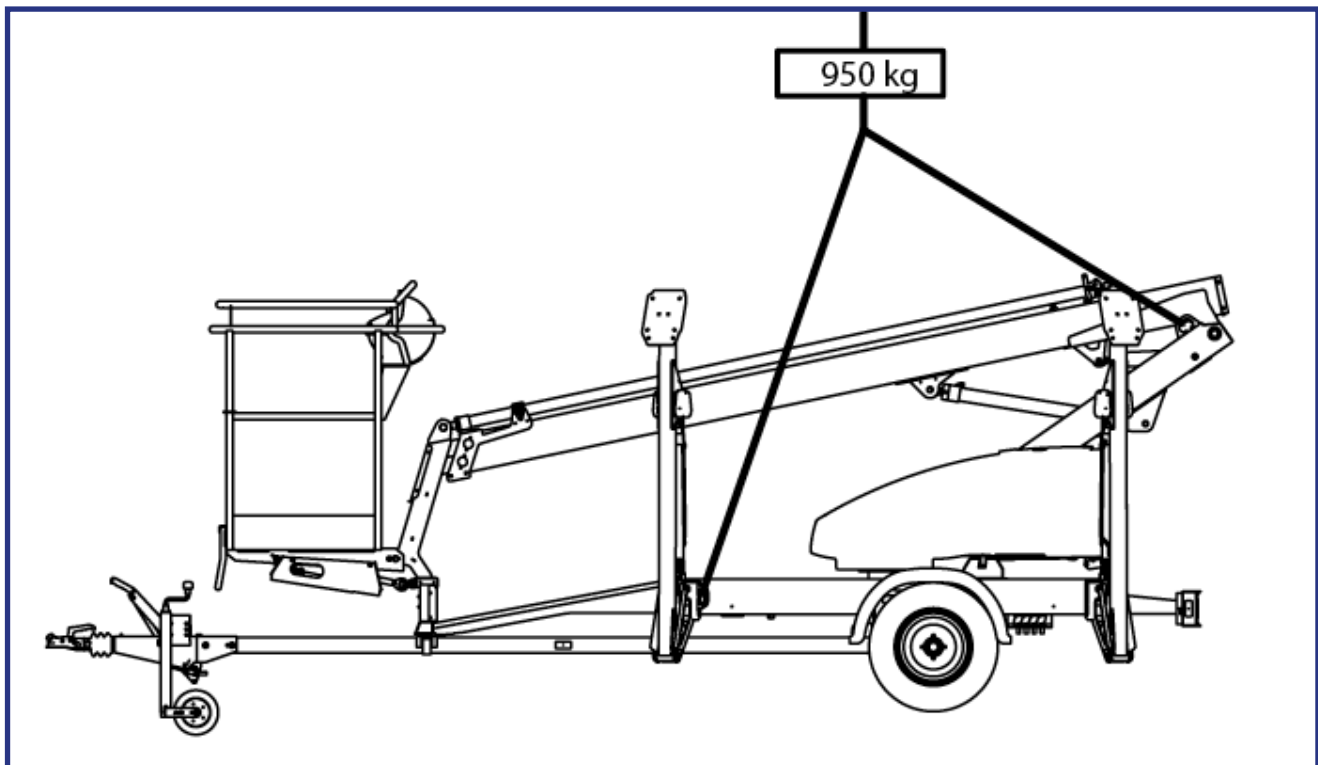



#### 5.4. LONG-TERM STORAGE

Clean the machine carefully, lubricate it and apply protective grease to it before putting it into long-term storage (see point “Lubrication plan”). Repeat the cleaning and lubrication procedures when resuming the operation.

### **NOTICE**

If you leave the lift standing for a longer period of time, for example over the winter, we recommend propping it up to release any load from the wheels.

The periodic inspections must be executed following the steps described in the instructions.

### 5.3. IN CASE OF EMERGENCY

#### 5.3.1. When at risk of losing the stability

Reduced stability can be caused by a fault in the lift, the wind or other lateral force, collapse of the standing base or negligence in providing sufficient support. In most cases one sign of reduced stability is the inclination of the lift.



1. If there is time, try to find out the reason for the reduced stability and the direction of its effect. Warn other people on the worksite using the alarm signal.



2. If possible, reduce the load from the platform in a safe manner.

3. Reduce the outreach to the side by retracting the telescope. Avoid abrupt movements.

4. Turn the boom away from the danger zone, i.e. to a position where the stability of the lift is normal.

5. Lower the boom.

If the stability has been lost as a result of a fault in the lift, repair such a fault immediately.



**Do not use the lift until the fault has been repaired and the condition of the lift has been verified.**

#### 5.3.2. In case of overloading



1. If there is time, try to find out the reason for the reduced stability and the direction of its effect. Warn other people on the worksite using the alarm signal.

2. If possible, reduce the load from the platform in a safe manner.



3. Reduce the outreach to the side by retracting the telescopic boom using the emergency descent system. Avoid abrupt movements.

#### 5.3.3. In case the power supply is interrupted

As a precaution against power failure or other malfunction of energy supply, the lift is equipped with a manually operated emergency descent system. Always check the condition of the emergency descent system before starting to use the lift.

**NOTE** Start by retracting the telescope completely, after that, lower the boom and last, turn the boom system.

The hand pump (A), the extension arm for the pump (B) and the turning crank of the boom (C) are located under the chassis control centre. The active movement is selected using the selector lever (D).

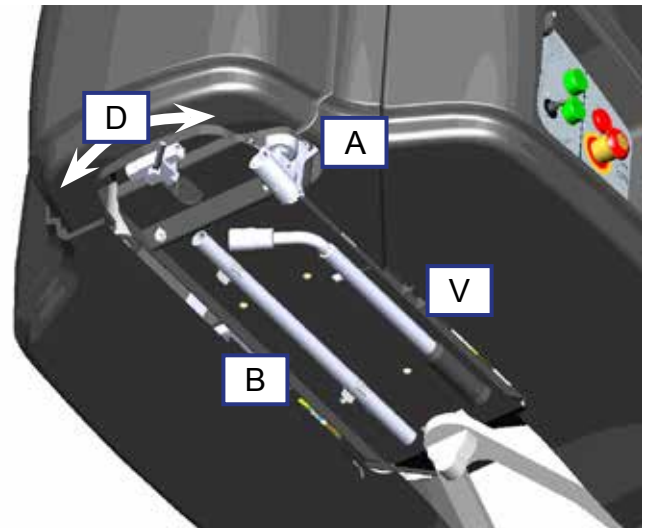

The emergency descent system can only be operated from the ground. If you are on the platform, call for help to operate the system.

### Operation:

1. Retracting the telescope  
Turn the selector lever to the left. Using the hand pump, retract the telescope completely.

2. Lowering the boom  
Turn the selector lever to the right. Using the hand pump, lower the boom completely.

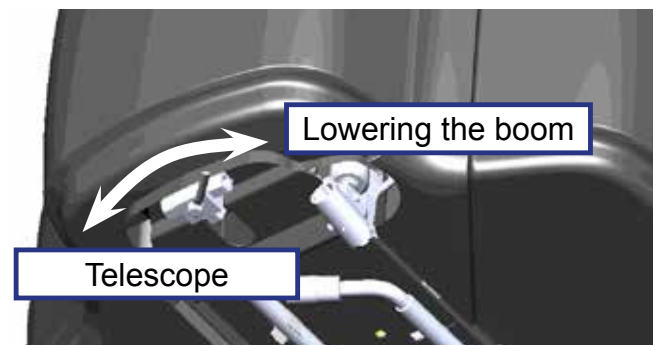

4. Turning of the boom  
To turn the boom, place the crank on the worm gear shaft in the opening in the plastic cover of the turning device. Turn the crank gently in the desired direction.

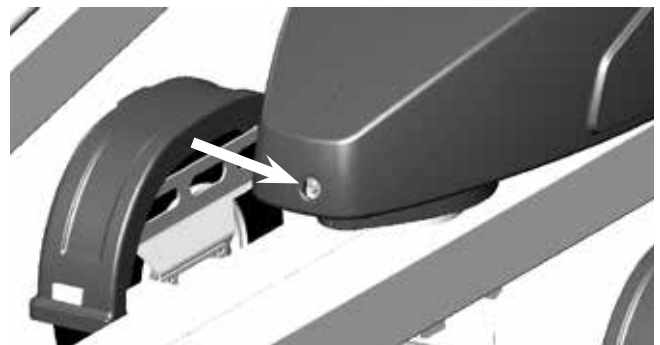

### 5.3.4. In case of malfunction, when even the emergency descent system is not operational

If not even the emergency system is working, try to warn other personnel present on the site or call for more help. When help arrives, try to

- restore the power supply required for normal operation of the lift
- resume the lift's normal operation by other means
- rescue the person on the platform by other means

## 6. INSTRUCTIONS FOR FAULT-FINDING

FAULT	REMEDY
-------	--------

### 1. The electric motor does not start from its start button although the selector switch 1 is in the position that enables operation from either the chassis or the platform control centre

Emergency stop button has jammed in its lowest position.	Pull up the button and re-start the motor from the start button.
Fuse F1 has blown.	Replace the fuse (10A).
No mains supply (230 VAC) to the selector switch.	Check the extension cords, possible distribution boards and fuses.
Fault current safety switch has tripped.	Reset the fault current safety switch.

### 2. No power supply to the lift, although the main switch is on and the selector switch is in either of the positions, which enable the operation from the chassis control centre or from the platform control centre

Power supply has not been activated.	Press the start button to activate the power supply.
--------------------------------------	--

### 3. None of the boom movements is operational, although the electric motor is running and the selector switch stands in the correct position (operation either from the chassis control centre or the platform control centre)

Green signal light for the outriggers is not illuminated.	Make sure that the outriggers are steady supported on the ground, and the tyres are off the ground.
---	---

### 4. Outriggers do not move

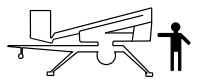
The boom is not resting on the transport support.	Drive the boom onto the transport support.
The selector switch is in the wrong position.	Turn the selector switch to the correct position. 
The limit switch on the boom support has not closed.	Drive the boom onto the transport support.

**FAULT****REMEDY****18. Driving device is not operational, although the selector switch is in the correct position**

Boom is not resting on the transport support.

Drive the boom onto the support.

**24. Wheel brakes overheat**

Parking brake not completely released.

Release the parking brake completely.

**25. Ball-coupling is not locked**

Inner parts of the ball-coupling dirty.

Clean and lubricate.

Tow-ball of the towing vehicle too large.

Make sure that the towing ball of the towing vehicle is the right size for the lift's tow hitch.

According to DIN74058, the diameter of the ball must be max. 50 mm and min. 49.5 mm.

**In all other fault conditions, the lift must be submitted to a qualified DINO service provider.**

**To avoid malfunctions**

- Follow the operating instructions
- Beware of dangerous situations, which can damage the lift
- Keep the lift clean and protect it against moisture

**NOTES**

**NOTES**

## 7. MAINTENANCE SCHEDULE

Service	Service interval	Service person	Instructed
A	Daily	Operator	operating instructions
B	every month/100 hours*	Competent person who is familiar with the lift	maintenance instructions
C	every 6 months/400 hours*	Competent person who is familiar with the lift	maintenance instructions
D	every 12 months/800 hours*	Technical specialist, who is well familiar with the structure and operation of the lift	maintenance instructions
E	When necessary	Technical specialist, who is well familiar with the structure and operation of the lift	maintenance instructions

\* Service interval in months or operating hours, depending on whichever comes first.

### NOTICE

In addition to the daily maintenance routines according to the maintenance schedule, every operator is obliged to perform a site-specific worksite inspection.

C = Check (general/visual checking of condition).

I = Thorough Inspection. To be performed following the procedure, described in the separate maintenance instructions.

M = Carry out lubrication, services, replacement of parts and repairs in accordance with this point.

Always lubricate the lift and apply a protective grease film immediately after the washing.

The lift must be subjected to an extraordinary inspection always after an exceptional event. An event is exceptional, for example, if the lift has been damaged so severely, that its strength or operational safety may have been endangered. Consult the maintenance manual for more detailed instructions.

### NOTICE

Under demanding conditions where moist, corrosive substances or corrosive climate may speed up the deterioration of the structures and induce malfunctions, the maintenance intervals must be shortened, or the influence of corrosion and malfunctions must be reduced by using appropriate protective agents.



Maintenance measures		A	B	C	D	E
1	Frame structures, boom system and platform	C	C	C	I	
2	Joints of the outriggers and the outrigger cylinders		M	C/M	I/M	
3	Joints of the outriggers' foot plates and the moving parts of the outrigger limits		M	C/M	I/M	
4	Bearings of the boom		M	C/M	C/M	
5	Bearings of the levelling system of the platform		M	C/M	C/M	
6	Articulation bearings of the levelling cylinders		M	C/M	C/M	
7	Articulation bearings of the lifting cylinders		M	C/M	C/M	
8	Sliding surfaces and rollers of the telescope		C/M	C/M	C/M	
9	Bearing of telescope cylinder			C/M	C/M	
10	Condition of cylinders				I	
11	Checking and adjusting the play between slide pads and surfaces		C	C	C	
12	Turning device and the swing movement limiter			M	I/M	
13	Tyres and tyre pressures	C	C	I	I	
14	Tow hitch/overrun		C	M	I/M	
15	Jockey wheel slide and threads				I/M	
16	Condition of brakes			C	C	
17	Axle and suspension				I	
18	Driving device		C	M	I	
19	Lights	C	C	C	I	
20	Hydraulic oils	C	C	C	M	
21	Hydraulic hoses, pipes and connections	C	C	C	I	
22	Condition and attachment of the electric appliances and wiring		C	C	I	
23	Hydraulic pressure				I	
24	Condition and attachment of safety devices				C	
25	Operation of safety devices (limit switches)	C	C	C	I	
26	Operation of load regulation valves			C	C	
27	Operation and condition of platform's levelling system		C	C	C	
28	Operation and condition of controls on platform	C			P	
29	Operation of emergency descent, emergency stop and sound signal	C	C	C	C	
30	Stickers, plates and instructions	C	C	C	C	
31	Test loading				I	
32	Anti-corrosion treatment				C	M
33	Special inspection					M

## 7.1. SCHEDULE FOR INSPECTIONS REQUIRED BY THE AUTHORITIES

**The inspections must be performed in accordance with local and national regulations, in accordance with the legislation and standards.**

The lift must be subjected to a **start-up inspection** before it is used for the first time and before starting it up the first time after a major repair or modification work.

The lift must be subjected to a thorough **periodic inspection** with related **test loading** at intervals of one year.

The inspection must be carried out within twelve (12) months of the first inspection or previous regular inspection.

In connection with the periodic inspection the lift must be subjected to a **non-destructive inspection/inspection disassembled** in general at intervals of ten (10) years from the start-up date.

In addition, the lift must be **inspected** to the extent applicable after any exceptional situation

The inspections of the lift must be carried out at regular intervals as long as it is in use. If the lift is used under extreme conditions, intervals between the inspections shall be reduced.

The overall operating condition of the lift as well as the condition of the safety-related control devices shall be established in the regular inspections. Particular attention shall be paid to changes, which affect the operational safety.

In connection with the regular inspection shall be established to what extent the lessons and practical experience gained since the previous inspection could be utilized to improve the safety even more.

For the inspection must be assigned an **expert inspection body with documented evidence of competence** or an **expert with documented evidence of competence**.

A **protocol** must be drawn up of the executed inspections. The protocols of the start-up and periodic inspections must be kept with the lift or its immediate proximity for at least five years.

### **NOTICE**

**Check the regulations for the inspections and the competence of the inspector with the local authorities.**

## 7.2. LUBRICATION PLAN

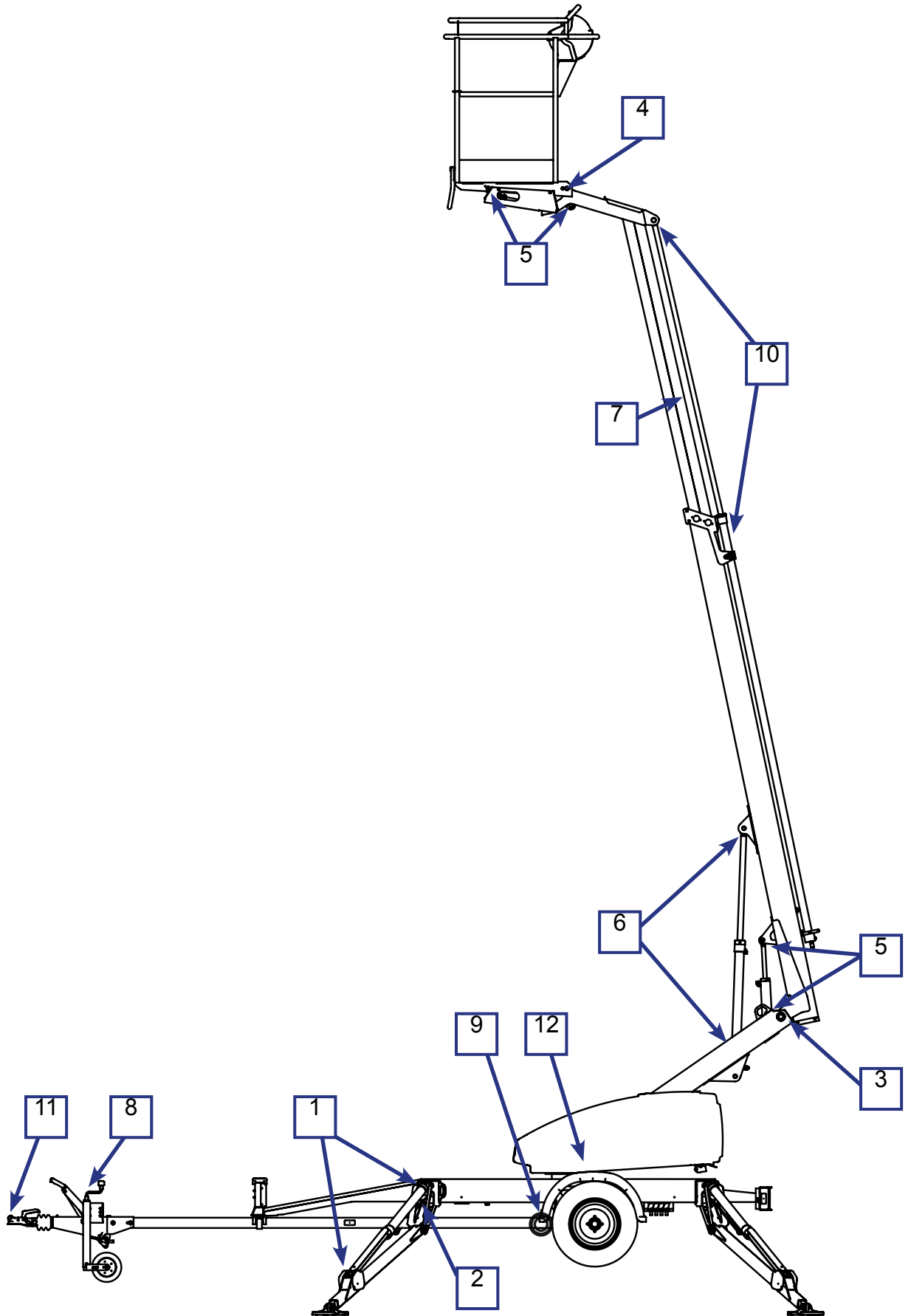

## 8. ROUTINE MAINTENANCE DURING OPERATION

The maintenance operations, that are the responsibility of the operator, are described in this chapter.

The more demanding maintenance operations that require special skills, special tools or specific measurements and adjustment values are instructed in the separate Maintenance Instructions. In such maintenance and repair cases, the operator shall contact an authorized service provider, the distributor or the manufacturer.

Make sure that all the service and maintenance procedures of the lift are performed in time and according to the given instructions.



### WARNING

Any such faults, observed during operation or periodic service, which affect the operational safety of the unit, must be repaired before the lift is used next time.

Keep the lift clean. Clean the lift especially carefully before services and inspections. Impurities may cause serious problems, for example, in the hydraulic system.

Use original spare parts and consumables. Consult the spare parts list for more detailed information about the parts.

#### **The first service after 20 hours of operation**

- change the pressure filter element
- adjust the brakes according to the instructions (see point “Wheel brakes and bearings”)
- check the wheel bolts for tightness after about 100 km of driving

**If the lift is operated under demanding conditions (in exceptionally humid or dusty environment, corrosive climate, etc.) the intervals between the oil changes and the other inspections shall be shortened to meet the prevailing conditions in order to maintain the operational safety and reliability of the lift.**

**The timely performance of the periodic servicing and the inspections is absolutely mandatory, because neglecting them may impair the operational safety of the lift.**

**The guarantee will not remain valid, if the servicing and the periodic inspections are not performed.**

## 8.1. INSTRUCTIONS FOR DAILY MAINTENANCE AND INSPECTIONS

### 8.1.1. Check the condition of chassis, the boom and the work platform

Check visually the condition of the access routes, the work platform, the platform gate and the handrails.

Check visually the condition of the boom and the frame structures.

### 8.1.2. Check the tyres and tyre pressure

Check visually that the tyres are duly inflated, and do not show any damage.

### 8.1.3. Check the lights

Check the condition of all the warning and signal lights as well as the road traffic lights of the trailer.

### 8.1.4. Check the hydraulic oil level

Check the hydraulic oil level with the platform in the transport position.

As required, top up hydraulic oil to the upper mark on the dipstick.

The hydraulic oil tank is located under a cover of the turning device, as shown in the picture.

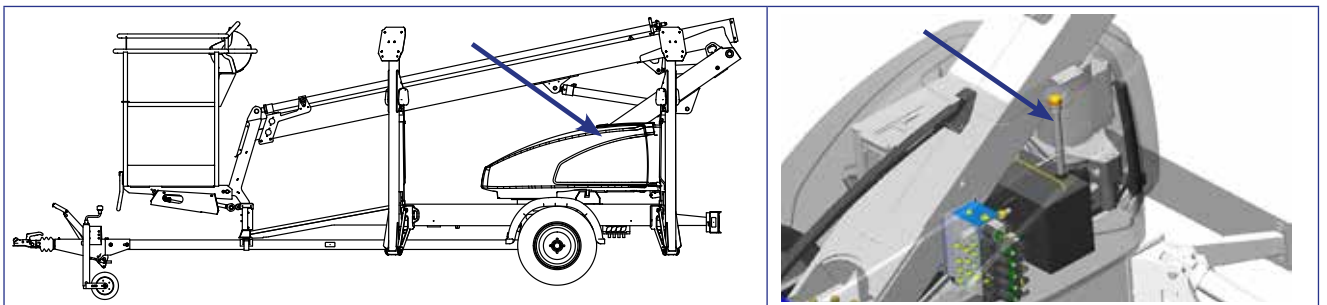

### 8.1.5. Check the hydraulic hoses, pipes and connectors

Check visually the hydraulic hoses, pipes and connections.

Make sure that there are no visible oil leaks.

Replace any externally damaged hoses and clashed pipes or fittings.

### 8.1.6. Check the operation of the safety limit switches

Test the operation of the safety limit switches that prevent the movements of the boom and the outriggers as follows:

1. The lift is in the transport position with the outriggers in the upper position, and the driving device connected.
2. Lift the boom via the controls in the chassis control centre.  
**The boom must not operate in any position of the selector switch.**
3. Lower the outriggers to the operating position of the lift
4. Using the controls in the chassis control centre, lift the boom so much that it raises from the support
5. Drive the outriggers.

**The outriggers must not operate in any position of the selector switch.**

### 8.1.7. Check the operation of the emergency descent, the emergency stop and the sound signal

Test the operation of the emergency stop and the emergency descent system from the chassis control centre LCB:

- lift the boom about 1–2 metres, and extend the telescope by 1–2 metres, keeping the emergency stop button depressed – the movement shall now stop
- using the emergency descent, retract first completely the telescope, then lower the boom
- pull up the emergency stop button

Test the operation of the emergency stop and the sound signal from the platform control centre.

### 8.1.8. Stickers, plates and instructions

Check that all the signs, warning decals and pictorials in the control centres are in place, intact and clean.

If the labels have started to come off or tear apart, or if the symbols or texts are illegible, then the decals must be replaced.

Product numbers of the decals are visible on the decals or the product numbers of new decal sets can be found in the spare part list.

Check that the user manuals accompanying the lift are legible.



**BLANK**





**BLANK**





## 9. CHANGE OF OWNER

For the owner of the lift:

If you have purchased a used DINO lift from some other than the manufacturer, please post your details to the manufacturer using the form on this page, and send it to:

info@dinolift.com

This information makes it possible for us to provide you with the safety bulletins and other campaigns relevant to your machine.

Note! It is not necessary to inform about a rented machine.

Machine model: DINO \_\_\_\_\_

Serial number: \_\_\_\_\_

Previous owner: \_\_\_\_\_

Country: \_\_\_\_\_

Date of purchase: \_\_\_\_\_

Current owner: \_\_\_\_\_

Address: \_\_\_\_\_

\_\_\_\_\_

Country: \_\_\_\_\_

Contact person

Name and position in the company: \_\_\_\_\_

Telephone: \_\_\_\_\_

E-mail: \_\_\_\_\_

**NOTES**

**NOTES**